

AIR EXHAUST SIDE

LOAD CONNECTION CONNECTORS

AIRFLOW



CONTROL POWER CONNECTOR

AIR INTAKE SIDE

SEE SHEET 2 FOR CASE DIMENSIONS

- 3. UNIT IS SUPPLIED WITH 10" [3m] LONG LOAD CONNECTION CABLES AND 115V POWER CABLE.
- 2. ALL DIMENSIONS ARE APPROX. IN INCHES [mm]
- 1. WEIGHT: 78 LBS [35.5 kg]



PORTABLE LOAD BANK WITH CASE
GENERAL REFERENCE OUTLINE DRAWING

Model 2500

1 OF 2

Rev. C

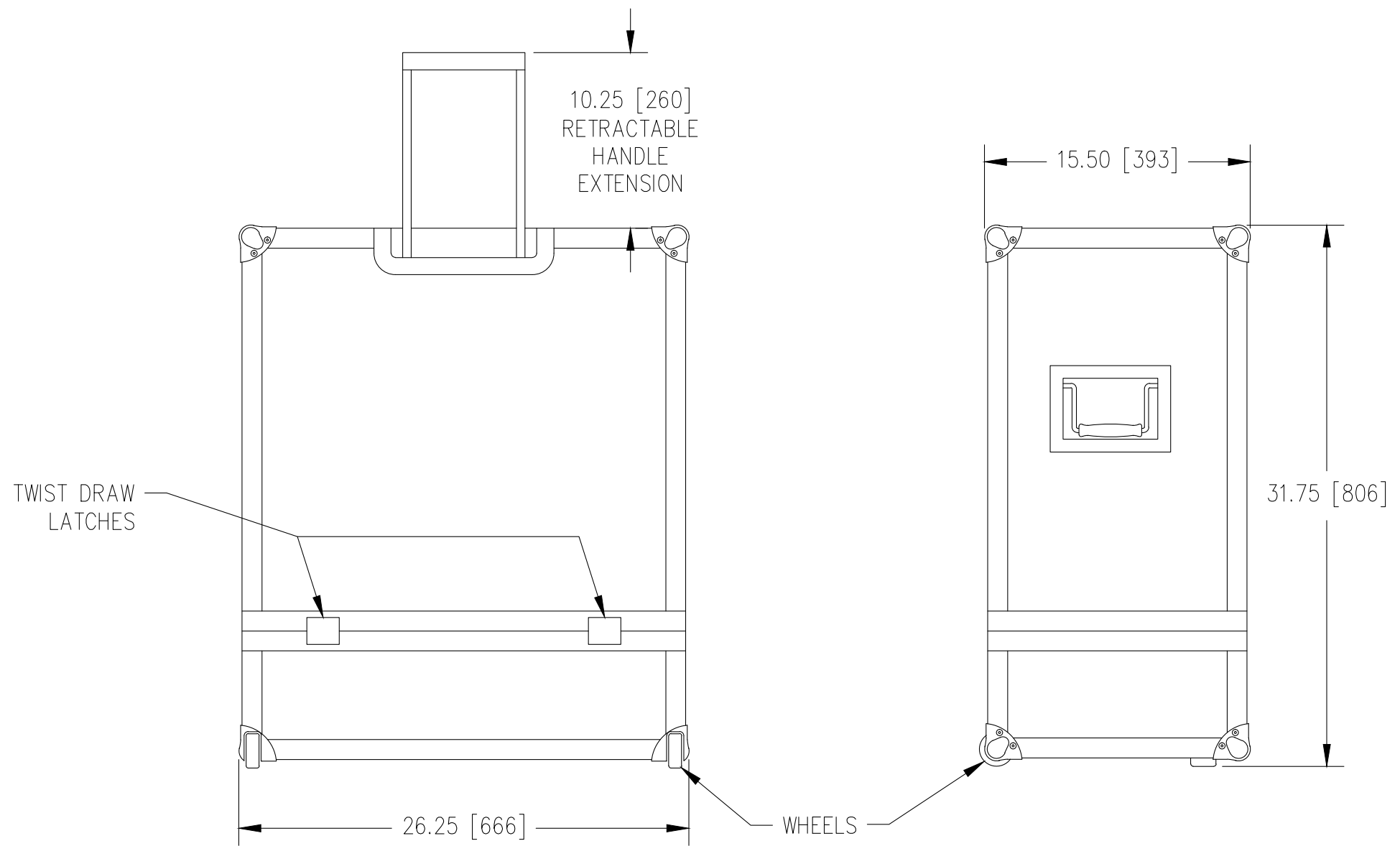

SEE SHEET 1 FOR LOAD BANK DIMENSIONS

2. ALL DIMENSIONS ARE APPROX. IN INCHES [mm]
1. WEIGHT: APPROX (CASE) 37 LBS [17 kg].



PORTABLE LOAD BANK WITH CASE
GENERAL REFERENCE OUTLINE DRAWING

Model 2500

2 OF 2

Rev. C